



MODEL NO: KO-PN16-40FT

GATE VALVE RISING STEM PN16/25/40BARS
 BOLTED BONNET, OUTSIDE SCREW AND YOKE
 FLEXIBLE WEDGE,
 AVAILABLE WITH GEAR OPERATOR
 FLANGED ENDS, BUTTWELDING ENDS
 APPLICABLE STANDARD: DIN 3352
 FACE TO FACE: PN25/16: DIN 3202 F5
 PN40: DIN 3202 F7
 END FLANGE: PN16: DIN2543
 PN25: DIN2544
 PN40: DIN2545
 INSPECTION AND TEST: DIN3230
 TEST PRESSURE: PN16: SHELL: 24BAR; SEAT: 17.6BAR
 PN25: SHELL: 37.5BAR; SEAT: 27.5BAR
 PN40: SHELL: 60BAR; SEAT: 44BAR
 DIN 50049-3.1B CERTIFICATE AVAILABLE



PARTS AND MATERIAL

NO.	PARTS NAME	MATERIAL
1	BODY	1.0619
2	SEAT FACE	13CR
3	DISC	1.0619+13CR
4	STEM	1.4006
5	GASKET	GRAPHITE+304
6	BONNET BOLT	ASTM A197 B7
7	BONNET NUT	ASTM A194 2H
8	BONNET	1.0619
9	BACKSEAT BUSHING	1.4006
10	STEM PACKING	GRAPHITE
11	GLAND	1.4006
12	GLAND FLANGE	1.0619
13	GLAND EYEBOLT	ASTM A197 B7
14	GLAND NUT	ASTM A194 2H
15	STEM NUT	BRASS ALLOY
16	HANDWHEEL	DUCTILE IRON
17	H.W. LOCK NUT	CARBON STEEL

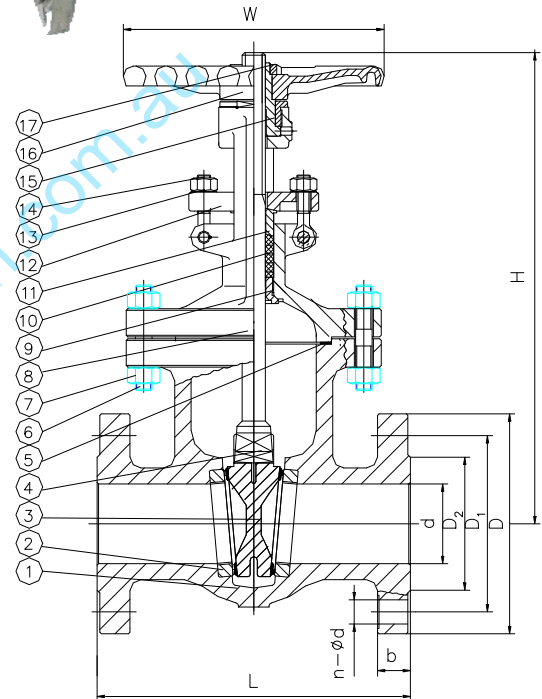

DIMENSIONS LIST:

UNIT: MM

KO-PN16FT (PN16)

DN	SIZE	d	D	D1	D2	b	n-φd	L(F5)	H(OPEN)	W
40	1-1/2"	40	150	110	88	18	4-18	240	380	200
50	2"	50	165	125	102	20	4-18	250	390	240
65	2-1/2"	65	185	145	122	20	4-18	270	490	240
80	3"	80	200	160	138	20	8-18	280	520	280
100	4"	100	220	180	158	20	8-18	300	580	320
150	6"	150	285	240	212	22	8-22	350	750	360
200	8"	200	340	295	268	24	12-22	400	900	400
250	10"	250	405	355	320	26	12-26	450	1150	450
300	12"	300	460	410	378	28	12-26	500	1240	560
350	14"	350	520	470	438	30	16-26	550	1350	640
400	16"	400	580	525	490	32	16-30	600	1560	720
500	20"	500	715	650	610	36	20-33	700	1920	720
600	24"	600	840	770	725	40	20-36	800	2150	800



KO-PN16FT (PN25)

DN	SIZE	d	D	D1	D2	b	n- φ d	L(F5)	H(OPEN)	W
40	1-1/2"	40	150	110	88	18	4-18	240	380	200
50	2"	50	165	125	102	20	4-18	250	390	240
65	2-1/2"	65	185	145	122	22	8-18	270	490	240
80	3"	80	200	160	138	24	8-18	280	520	280
100	4"	100	235	190	162	24	8-22	300	580	320
150	6"	150	300	250	212	28	8-26	350	750	360
200	8"	200	365	310	278	30	12-26	400	900	400
250	10"	250	425	370	335	32	12-30	450	1150	450
300	12"	300	485	430	395	34	12-30	500	1240	560
350	14"	350	555	490	450	38	16-33	550	1350	640
400	16"	400	620	550	505	40	16-36	600	1560	720
500	20"	500	730	660	615	44	20-36	700	1920	720
600	24"	600	845	770	720	46	20-39	800	2150	800

KO-PN40FT (PN40)

DN	SIZE	d	D	D1	D2	b	n- φ d	L(F7)	H(OPEN)	W
40	1-1/2"	40	150	110	88	18	4-18	240	390	200
50	2"	50	165	125	102	20	4-18	250	410	280
65	2-1/2"	65	185	145	122	22	8-18	290	520	280
80	3"	80	200	160	138	24	8-18	310	530	320
100	4"	100	235	190	162	24	8-22	350	600	360
150	6"	150	300	250	212	28	8-26	450	770	400
200	8"	200	375	320	285	34	12-30	550	920	450
250	10"	250	450	385	345	38	12-33	650	1170	560
300	12"	300	515	450	410	42	16-33	750	1260	640
350	14"	350	580	510	465	46	16-36	850	1450	640
400	16"	400	660	585	535	50	16-39	950	1600	720

We hereby reserve the rights of any alternative dimension that would help to improve our valve's quality and working efficiency