



Ductile Iron Groove End
Butterfly Valve

Model: 81-G Series

Rating: Class 125



Design feature:

- Suitable for use in mechanical rooms, process lines, water lines, and cold/hot water pipelines.
- Available in Lever Handle and Gear Operator
- Nickel plated ductile iron disc are available as standard feature. Optional BUNA-N or EPDM encapsulated with ductile iron disc for bubble tight shutoff.
- Groove end designed to ANSI/AWWA C-606 Rigid Groove Specifications.
- Groove End compatible with IPS pipe.
- Concentric disc design
- Two piece shaft design of the disc, increasing cycle life.
- ISO 5211 mounting flange accommodates automation installations, including pneumatic and electric actuators.

Standard:

- ANSI/AWWA C-606 Specifications.
- Face to face according to MSS SP-67 Standards
- Design according to API 609
- Inspection & testing according to API 598.
- PED 97/23/EC; ISO 9001

Specifications:

- Flow bore: full port.
- Rating: Class 125
- Temperature: -20 °F to 220 °F (-29°C to 104 °C).
- Materials: Ductile Iron
- Size range: DN50 – DN300

Material List

No.	Part Name	Material
1	Stub Screw	Carbon Steel
2	Bottom Shaft	SS 416
3	Disc	Ductile Iron Nickel Plated
4	Top Shaft	SS 416
5	Body	GGG50
6	O-Ring	EPDM
7	Bolt	Carbon Steel
8	Washer	Carbon Steel
9	Gearbox	Cast Iron

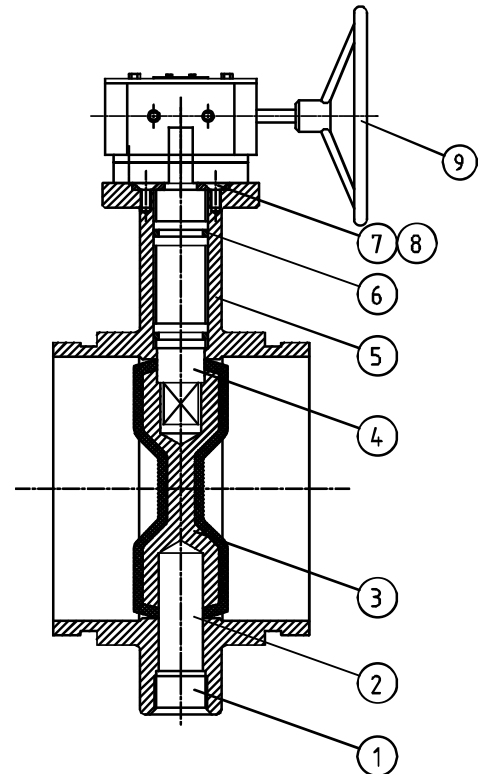

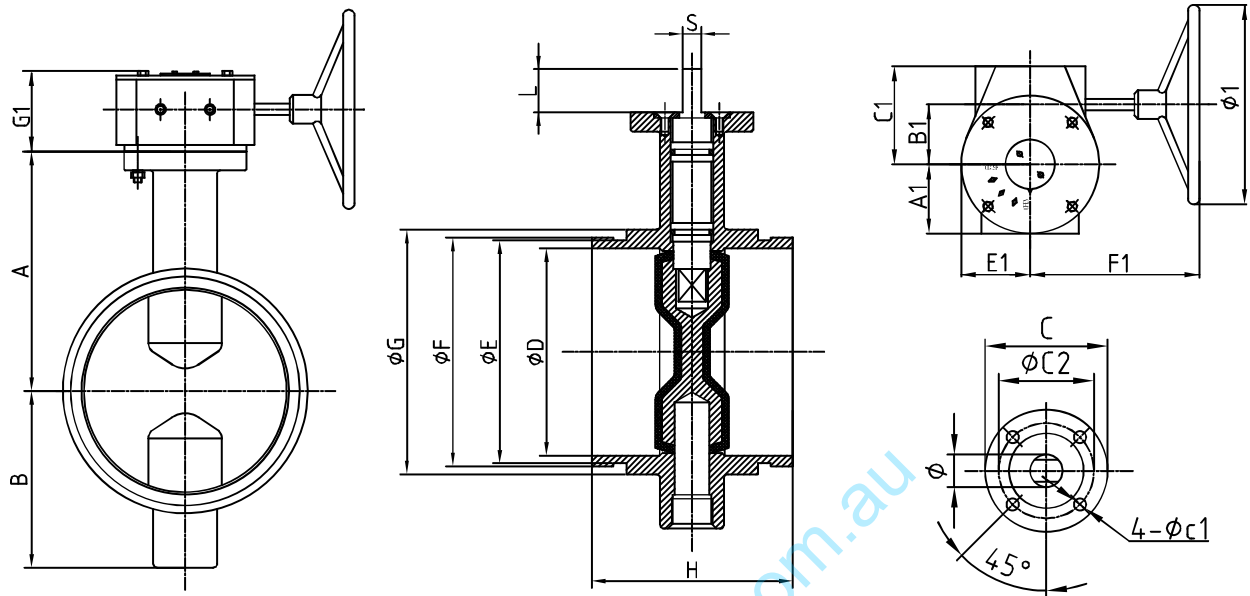

Dimensions List:

	A	B	H	D	E	F	G	Φ	L	C	C1	C2	S	Top Flange
DN50	100	70	83	51	57	60	67	12.6	32	90	10	70	10	F07
DN65	106	75	97	64	69	73	80	12.6	32	90	10	70	10	F07
DN80	113	82	97	76	85	89	97	12.6	32	90	10	70	10	F07
DN100	135	100	116	100	110	114	123	15.7	32	90	10	70	12	F07
DN125	148	119	148	128	137	141	151	19	32	90	10	70	14	F07
DN150	176	130	148	152	164	168	180	19	32	90	10	70	14	F07
DN200	204	162	134	203	214	219	231	22	45	125	12	102	17	F10
DN250	228	200	159	253	268	273	284	28.5	45	125	12	102	22	F10
DN300	266	234	164	303	318	324	335	32	45	125	12	102	24	F10

Gearbox Dimension:

Gearbox	A1	B1	C1	E1	F1	G1	Φ1
DN50-DN150	52	45	75	52	152.5	75	150
DN200-DN250	75	63	101	75	250	86	300
DN300	81	80	118	81	227	83	300

Note: due to continuous development of the products, DIE ERSTE reserves the right to change the dimension and information contained in the document as required.